

Please contact us for further details

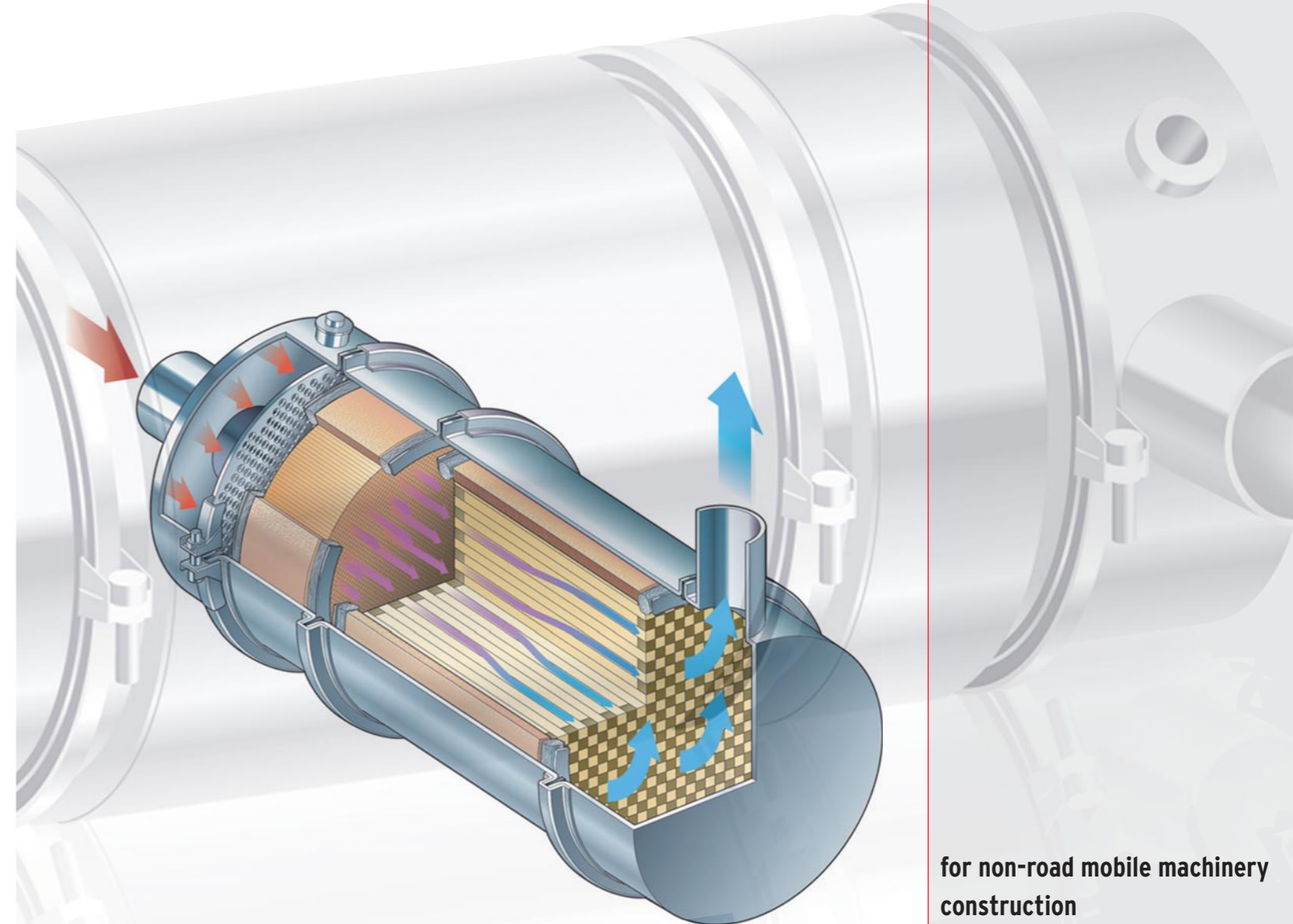

Johnson Matthey



PRO NATURE
DIESEL PARTICULATE FILTERS

for non-road mobile machinery
 construction
 agriculture
 forestry
 materials handling
 mining
 rail and marine applications
 stationary engines
 compressors
 municipal vehicles
 from 1 kW up to > 1000 kW

Customers all over the world benefit from Johnson Matthey's experience, innovations and the certified and approved quality of our products and services.

Johnson Matthey GmbH
 Otto-Volger-Str. 9b · D-65843 Sulzbach/Ts.
 Tel. +49(0)6196-703813 · Fax +49(0)6196-72450
 www.jmnonroad-eu.com



Johnson Matthey

Diesel-Partikel-Filter

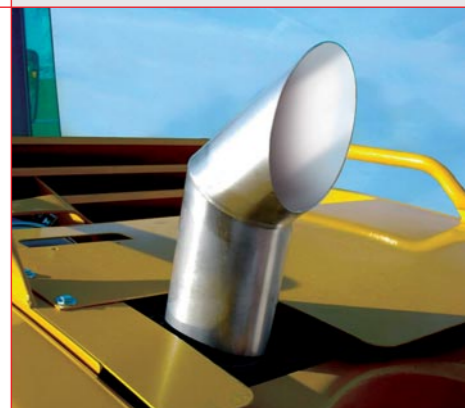

Why Diesel Emissions Control?

Diesel engines move the world. However, they pollute.

Concerns over the adverse health effects of diesel exhaust have prompted regulations designed to cut particulate matter emissions.

The outcome has been a growing demand for diesel emissions control systems.

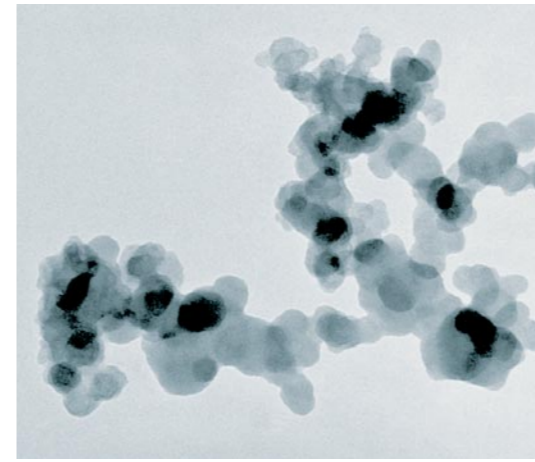

By virtue of their durability and fuel efficiency, diesel engines are the power source behind commercial transport, as well as off-road equipment for mining and construction.

Identified as a toxic air contaminant, diesel engine exhaust contains gaseous pollutants and particulate matter (PM), comprising carbon soot and a soluble organic fraction (SOF) that can condense on the soot.

How Are Diesel Emissions Controlled?

The answer to the problem of diesel pollution is to filter particulate from the exhaust using a diesel particulate filter (DPF).

PM trapped inside the filter must be removed periodically to prevent the filter from blocking. This filter regeneration is key to an effective emissions control system.

Johnson Matthey's DPF technology is unique in this field because of the flexibility it offers to users. Johnson Matthey has developed three different approaches to filter regeneration and incorporated them in a modular design concept that allows the use of different regeneration modes as circumstances require.

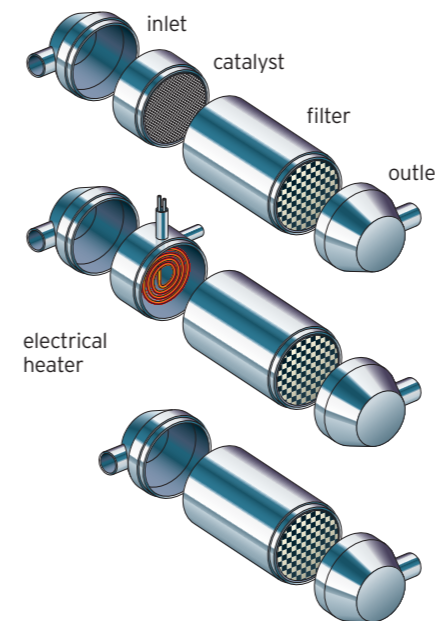
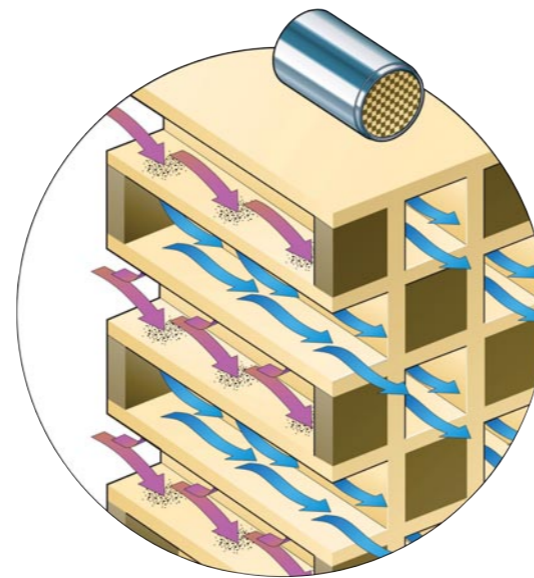

Johnson Matthey's Regeneration Techniques:

Type	Regeneration Technique	Used When
DPF-(C)CRT®	The Continuously Regenerating Trap (CRT®) uses a catalyst in front of the filter. As well as oxidising the SOF, the catalyst generates nitrogen dioxide that removes soot from the filter	DPF-(C) CRT: When low sulphur diesel is available, exhaust gas temperature >220° C / 250° C, NOx:PM ratio >25
DPFI	An electrical heater is used to raise the temperature inside the filter to burn away the PM	Equipment runs on higher sulphur fuel and when low engine speeds/loads give rise to low exhaust temperatures
DPFIS	A fuel additive is metered into the diesel fuel. It acts as a catalyst, oxidising the PM trapped in the filter	Equipment runs on higher sulphur fuel and duty cycle gives high exhaust temperatures

Benefits of Johnson Matthey's DPF Technology

Johnson Matthey's DPF technology is specifically designed for non-road vehicles.

The versatile DPF systems approach means that there is a solution for every application, regardless of fuel quality, duty cycle or engine emissions. Systems are capable of fitting engines with power ratings from a few kW to >1MW.

The selection and sizing of systems is based on Johnson Matthey's expertise in emissions control combined with its experience supplying the non-road sector.

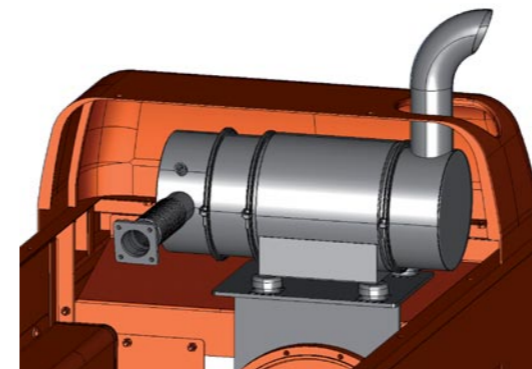

The DPF systems are fabricated in stainless steel housings mechanically robust enough to survive in the non-road environment. The modular design allows easy servicing and all systems have electronic monitoring capability.

Wherever government approvals are required these have been secured.

Support and service is provided locally but utilising Johnson Matthey's global network of technology, sales and manufacturing plants.

